



^{58th} JAPAN GOLF FAIR 2024

EXHIBITORS MANUAL

8th 9th 10th March 2024

PACIFICO YOKOHAMA Exhibition Hall

Exhibitor Application Period

20th Nov. 2023 – 22nd Dec. 2023

www.japangolffair.com/en



Japan Golf Goods Association

INTRODUCTION

Thank you very much for applying to exhibit at 58th Japan Golf Fair 2024.

The exhibitor guidelines have been drawn up to aid exhibitors at JGF 2024 as well as related companies cooperating with exhibitors in preparing for the Fair.

The guidelines provide various rules and instructions regarding exhibiting at JGF 2024; from preparing your exhibit, to removing exhibits from the venue after the fair.

Please read this guideline carefully to aid in the preparation of your exhibit.

We hope JGF 2024 will serve as a unique opportunity for the exchange of information, business conferences and for expanding business opportunities for all participants.

CONTENTS

■ Overview	1
■ Regulations of JGF2024	2
■ Booth types and specifications of Exhibit	3
■ Optional Facilities	6
■ Overall Schedule	7
■ Entry to the Exhibition Hall	8
■ Guidelines for Moving Goods in and out of the Fair Grounds	9
■ List of Application forms	13
■ Payment other than exhibition fee	13
■ Guidelines for Decoration and Exhibition	14
■ Supply of Electricity	17
■ Points of Attention for the Fire Prevention	20
■ Demonstrations and Advertising Activities	22
■ Regulations on Sale within exhibitor booths	25
■ Maintenance and Management of the Fair	26
■ Regulations for exhibitions and PR activities	27
■ Rental Furniture Catalog	Separate Volume

Overview

- Name: 58th Japan Golf Fair 2024
- Dates: 8(Fri.) 9(Sat.) 10(Sun.) March 2024
- Hours: 10:00 - 18:00 (10:00 - 17:00 on the last day)
- Venue: PACIFICO YOKOHAMA Exhibition Hall
1-1-1 Minato Mirai, Nishi-ku, Yokohama 220-0012, Japan
- Organizer: Japan Golf Goods Association
- Sponsors: Ministry of Economy, Trade and Industry
Yokohama City
Japan Golf Association
Japan Golf Range Association
Japan Golf Courses Employers Association
Japan Public Golf Society
The Professional Golfers' Association of Japan
Japan Golf Tour Organization
Japan Ladies Professional Golfers' Association
Greenery by Golf Group
The Golf Tournament Promotion Association of Japan
Turfgrass Research & Development Organization of Japan
Japan Golf Journalist Association
Japan Golf Tour Players Club
- Supported: Yokohama Convention & Visitors Bureau
- Admission prices: 1,500JPY (1,000JPY Pre-sell)
- Expected visitors: 35,000
- Planning: Japan Golf Goods Association
Fair Committee /Japan Golf Fair 2024 Executive Committee
- Administration: Japan Golf Fair Operational Secretariat
1-6-5 , Shibadaimon, Minato-ku, Tokyo
105-0012 Japan,
Email : exhibitor@japangolffair.com

Inquiries

Japan Golf Fair Operational Secretariat

Email : exhibitor@japangolffair.com

Exhibition Regulations of JGF2024

- Exhibitor booth locations will be determined by the organizer.
- Please adhere to the fair's operating hours. Dismantling is prohibited during the operating hours.
- Throughout JGF 2024, from the setup of goods to the removal of all exhibited items, exhibitors must wear an ID badge to access the fairgrounds.

Inquiries

Japan Golf Fair Operational Secretariat
Email : exhibitor@japangolffair.com

Booth types and specifications of Exhibit - 1

Type A Booth

- ★ W3.5m ×D3.0m ×H2.7m
- ★ Three-sided walls (system panels) partitions booths off from neighboring booths.
- ★ Two-sided walls are used for corner booths.
- ★ Type A booths are only separated from neighboring booths by partitioning walls. Power supplies and exhibition equipment, etc., are to be arranged by the exhibitors.
- * Power supplies and exhibition equipment, etc., can also be arranged at a fee by the JGF Operational Secretariat.

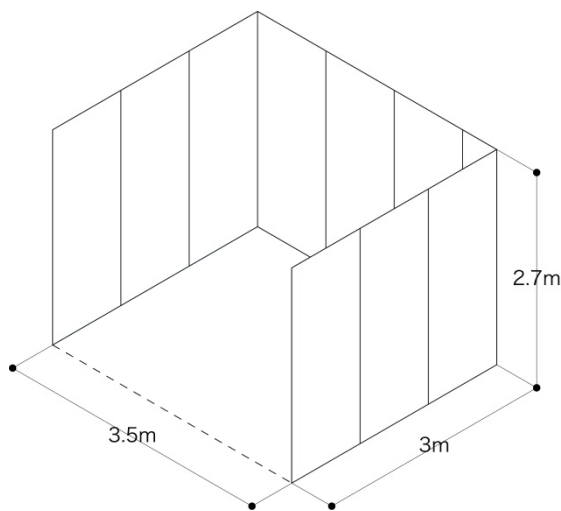

✳️Type A open booth (More than 6 booths)

As for open booths, back and side panels will not be provided. Only the measured floor space will be allocated in accordance with the number of the booths you requested. Each exhibitor is responsible for their own decorations.

Type A Booth Package Plan (Only for single booths)

- ★ Package Plan includes power supplies and exhibition equipment in sets.

▪ Parapet	system parts
▪ Punch Carpet	color choice is available (red, blue, green)
▪ Company Name Board	Cutting Sheet, unified letter font
▪ Fluorescent light (LED)	21W, 2 lights
▪ Spot Light (LED)	16W, 5 lights
▪ Electrical Outlet	100V/500W 2 prong receptacle
▪ Trunk-Line Electrical Work	1KW limit
▪ Reception counter	1 (W900mm X D450mm X H800mm)
▪ Folding chairs	2
▪ Trash Can	1
▪ Visiting Card Tray	1
▪ Catalog Stand	1
▪ Display Net with hooks	1 (10 hooks)

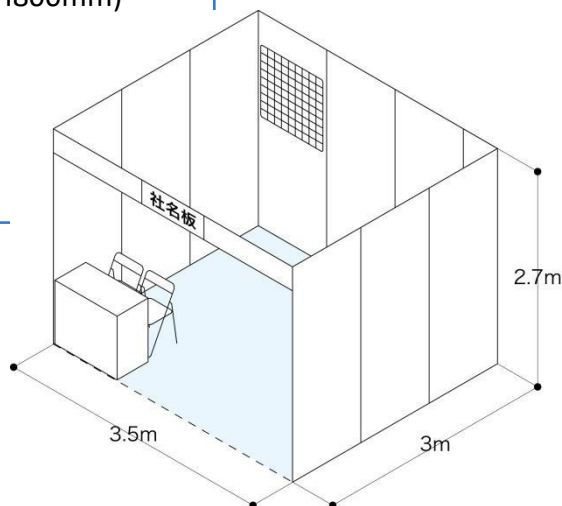

Booth types and specifications of Exhibit - 2

Type B Booth

- ★ W2.0m ×D2.0m ×H2.7m
- ★ Three-sided walls (system panels) partitions booths off from neighboring booths.
- ★ Two-sided walls are used for corner booths.
- ★ Type B booths are only separated from neighboring booths by partitioning walls. Power supplies and exhibition equipment, etc., are to be arranged by the exhibitors.
- * Power supplies and exhibition equipment, etc., can also be arranged at a fee by the JGF Operational Secretariat.

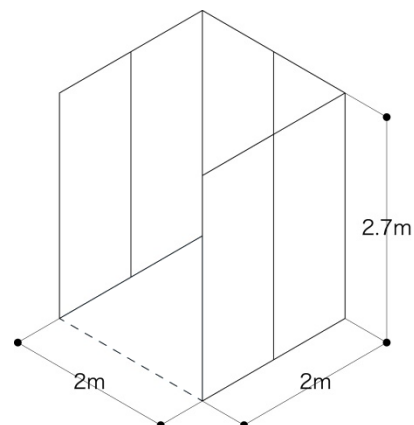

Type B Booth Package Plan (Only for single booths)

- ★ Package Plan includes power supplies and exhibition equipment in sets.

▪ Parapet	system parts
▪ Punch Carpet (red, blue, green)	color choice is available
▪ Company Name Board	Cutting Sheet, unified letter font
▪ Fluorescent light (LED)	21W, 1 lights
▪ Spot Light (LED)	16W, 2 lights
▪ Electrical Outlet	100V/500W 2 prong receptacle
▪ Trunk-Line Electrical Work	1KW limit
▪ Reception counter	1 (W900mm X D450mm X H800mm)
▪ Folding chairs	2
▪ Trash Can	1
▪ Visiting Card Tray	1
▪ Catalog Stand	1
▪ Display Net with hooks	1 (10 hooks)

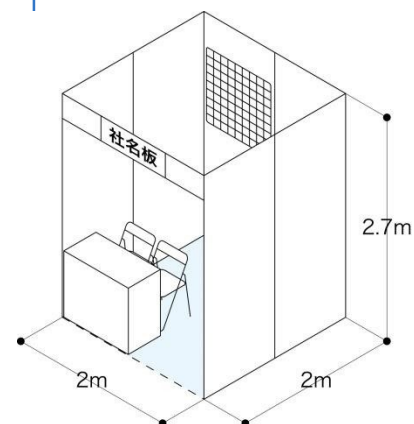

Booth types and specifications of Exhibit - 3

Hitting Booth with Display Space (Single booth per company)

★ Hitting booths include a 6 square-meter display space

★ Display Space Size:

W6.0m × D1.0m × H2.7m

★ Hitting Booth Size :

W3.0m × D6.0m × H3.0m

※Using net booth for other purpose than trial hitting is prohibited.
(ex. Exhibiting and business talk)

※For safety, keep hitting booth and Display space 50 cm. apart.

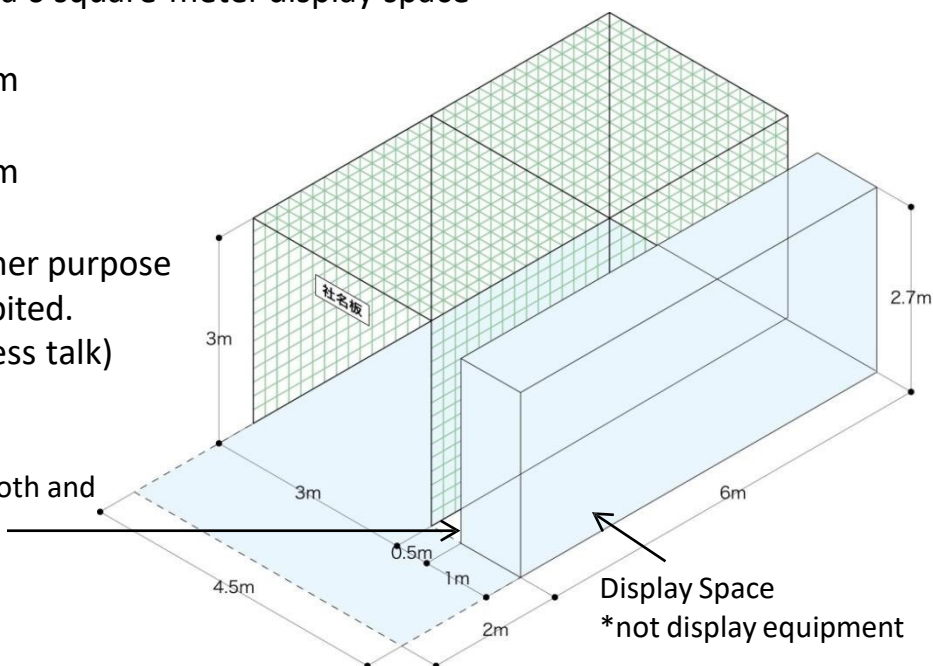

Display Space
*not display equipment

Hitting Booth with Display Space Package Plan

★ Package Plan includes power supplies and exhibition equipment in sets.

- | | | |
|------------------------------|------------------------------|--------------------|
| ▪ Electrical Outlet | 100V/500W | 2 prong receptacle |
| ▪ Trunk-Line Electrical Work | 1KW limit | |
| ▪ Reception counter | 1 (W900mm X D450mm X H800mm) | |
| ▪ Folding chairs | 2 | |

Wall Exhibition Booth Type (Single booth per company)

★ W2.0m × D1.0m × H2.7m

★ This booth type includes power supplies and exhibition equipment in sets.

※Displaying on the floor and protruding from the frame are prohibited.

- | | | |
|--------------------------|-----------------------------|--|
| ▪ Side walls | 2 (Depth 495mm) | |
| ▪ Display Net with hooks | 1 (10 hooks) | |
| ▪ Display Shelves | 2 | |
| ▪ Spot Light (LED) | 16W, 2 lights | |
| ▪ Electrical Outlet | 100V/1KW 2 prong receptacle | |

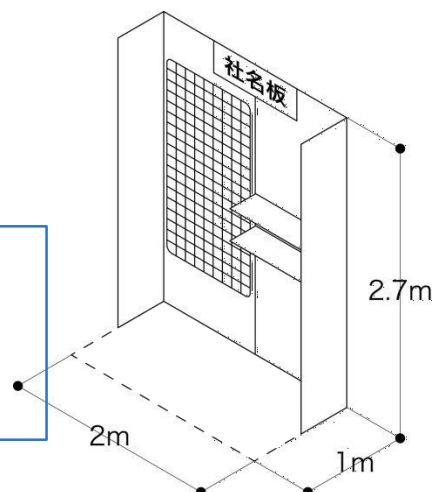

Optional Facilities

Hitting Booth Cage Type

- ★ Hitting Booth Size : W3.0m ×D8.0m ×H3.0m
- ★ Limited to Type A booth exhibitors

Hitting Booth Open Type

- ★ Hitting Booth Size : W2.7m ×D18.0m ×H6.0m
- ★ Limited to type A booth exhibitors operating six or more booths

Rental Space (L) 22.5m²

- ★ Limited to type A booth exhibitors operating four or more booths
- ★ Located inside the exhibition hall

Rental Space (S) 14m²

- ★ Limited to type A booth exhibitors
- ★ Located inside the exhibition hall

Inquiries

Japan Golf Fair Operational Secretariat
Email : exhibitor@japangolffair.com

Overall Schedule

8 Mar. (Fri.)	07	08	09	10	11	12	13	14	15	16	17	18	19	20	21	22	23	24	
	Early work (payable) 7:00~ 8:30		Japan Golf Fair 10:00~ 18:00									Overtime work 18:00~		Overtime work (payable) 21:00~7:00					
		●Open for exhibitors 8:30																	
9 Mar. (Sat.)	07	08	09	10	11	12	13	14	15	16	17	18	19	20	21	22	23	24	
	Early work (payable) 7:00~ 8:30		Japan Golf Fair 10:00~ 18:00									Overtime work 18:00~		Overtime work (payable) 21:00~7:00					
		●Open for exhibitors 8:30																	
10 Mar. (Sun.)	07	08	09	10	11	12	13	14	15	16	17	Never start dismantling until 17 : 00.							
	Early work (payable) 7:00~ 8:30		Japan Golf Fair 10:00~ 17:00									17:10~ Carrying out exhibits 17:20~ Removal of decoration 18:00~ Exhibitor's vehicle entry is possible 19:00~ Decorator's vehicle entry is possible							
		●Open for exhibitors 8:30																	

*Application for early and overtime work is required.

Never start dismantling until 17 : 00.

Entry to the Exhibition Hall

During the entire JGF 2024, from installation of goods to the removal of all exhibited items, all exhibitors will be required to put on an ID badge identifying their eligibility to enter the Fair grounds. This is requested in order to prevent any accidents or theft. No one will be admitted to the premises without a badge. All participants of the Fair are requested to cooperate fully with this rule.

■ Exhibitor's badge (during the fair)

All staff members are required to put on exhibitor badges when entering the premise. Exhibitor badges will be handed out at JGF Operational Secretariat in the exhibition hall on **8 and 9 Mar.**, the booth preparation days.

*Stipulate number of exhibitor badges

1~2 booth(s) will receive **6 badges per exhibitor**

3~5 booths will receive **15 badges per exhibitor**

More than 6 booths will receive **3 badges per booth**

■ Worker's Badge

[Installation & Decoration Workers] *Invalid during the fair

Workers that will decorate the booths must put on a worker's badge to enter the venue.

Worker badges will be handed out at JGF Operational Secretariat on **7 Mar.**, the booth decoration day.

*Stipulate number of worker's badges

1~2 booth(s) will receive **6 badges per company**

3~5 booths will receive **15 badges per company**

More than 6 booths will receive **3 badges per booth**

Guidelines for Moving Goods in and out of the Fair Grounds - 1

■ Preparation schedule

6 Mar. (Wed.)	09:00 ~ 18:00	Booth Decoration
7Mar. (Thu.)	09:00 ~ 18:00	Loading of exhibits and Exhibit display
10 Mar. (Sun.)	17:10 ~	Carrying out exhibits
	17:20 ~	Removal of Decoration Equipments
	18:00 ~	Exhibitors Moving-out by Vehicles
	19:30 ~	Decorators Moving-out by Vehicles

■ Work days / times and overtime

The date and times for work days prior to the fair are as follows:

Booth decoration: 6 Mar. (Wed.) 09:00 – 18:00

Loading of exhibits and Exhibit display: 7Mar. (Thu.) 09:00 – 18:00

Overtime at no extra cost is possible from **18:00 to 20:00** on both days upon application.

Please submit applications for overtime **by 18:00** to JGF Operational Secretariat.

Overtime **before 09:00** and **after 20:00** is charged at **20,000 yen** per hour.

■ Conveyance and display of exhibits

March18(Wed.) is the designated day for bringing in and displaying exhibits.

In principle, exhibitors are not permitted to carry out decorative work on this day.

Vehicles for bringing in exhibits can be driven up to the service yard in front of the exhibition hall's service entrance, but cannot be driven into the exhibition hall.

Exhibitors are recommended to use carts to bring in their exhibits.

(JGF Operational Secretariat does not provide loans of carts, so exhibitors should prepare these themselves.)

Exhibitors using vehicles are required to show an "Exhibitor Conveyance Vehicle Pass" at the front window. These passes will be handed out at JGF Operational Secretariat in the exhibition hall.

■ Vehicle Pass

All vehicles for decoration work and move in must have a vehicle pass. One pass per one vehicle is necessary.

*Stipulate number of vehicle passes

Vehicle passes for decorators (valid on 8 and 12 Mar.)

3 passes per company

Vehicle passes for exhibitors (valid on 9 and 12 Mar.)

2 passes per exhibitor

The Japan Golf Fair requests all exhibitors to work with a minimum number of vehicles in order to promote a smooth move in.

Guidelines for Moving Goods in and out of the Fair Grounds - 2

■ Direct Shipments to the Exhibit Site

Please send any exhibits or related materials to the below address.

Address: **PACIFICO YOKOHAMA Exhibition Hall**
1-1-1 Minato Mirai, Nishi-ku, Yokohama 220-0012, Japan

Event name: **JAPAN GOLF FAIR 2017**

phone: **+81-45-221-2155**

Name of Exhibiting Company: Your Company name

Booth No.: Your booth number

To Arrive (date): _____

Neither the exhibition hall nor JGF Operational Secretariat can take care of items that exhibitors send.

Exhibitors are requested to collect their items in person on the booth decoration and preparation days.

*When you schedule to ship all exhibition items to the Fair, please make plans to ship them back as soon as the Fair is over. PACIFICO YOKOHAMA does not have any storage facilities for exhibitors. Exhibitors' displays and products must be shipped out immediately after the Fair is over **10 Mar.**

We recommend YAMATO GLOBAL LOGISTICS JAPAN CO., LTD. as a shipping agency.

***Foreign exhibitors are allowed to sell products on the last day of the Fair.**

■ Bonded Exhibits

Please contact international forwarders in your country, if you are planning to display bonded exhibits.

We recommend **YAMATO GLOBAL LOGISTICS JAPAN CO., LTD.** as forwarder.

Please refer to the Shipping Manual.

Guidelines for Moving Goods in and out of the Fair Grounds - 3

■ **Moving in and Moving out of Exhibits during the Fair Period**

As a general rule, moving in and out of exhibits is not permitted during the fair period. However, in cases of unavoidable circumstances such as exhibit issues, damage, or the need to restock materials, you must seek approval from the Operational Secretariat by submitting a 'move-in notification' in advance. Ensure that the exhibition's representative is present during the process. For security reasons, moving items in and out is only allowed before and after the JGF operating hours.

※ **During the Fair, visitors are allowed to bring their own golf clubs in and out of the hall.**

Taking golf products in or out of the Fair will be permitted on the following occasions:

1. When a move-out permission sticker is attached to the product
 - 1) A product with a sticker attached by the staff of the JGF at the entrance
 - 2) An Exhibitors' prize with a permission sticker attached
 - 3) A product for sale at the Fair only with a permission sticker attached

*Even if a visitor has won a prize, a permission sticker must be attached or they will not be allowed to bring the goods out of the venue.
2. When a temporary move-out permission badge is held by or attached to a product being carried by an exhibitor with a badge before opening and after closing hours.

If an exhibitor's plan requires this sticker or badge, please request to JGF Operational Secretariat.

Guidelines for Moving Goods in and out of the Fair Grounds - 4

■ Moving out of Exhibits

The schedule for moving out is below.

10 Mar. (Sun.)

09:00 - "Service entrance" (temporary parking lot) opens for vehicles.

The "move-in and out vehicle pass" must be displayed on the vehicle windshield. Please park your vehicle following the security staff's instructions.

17:10 -Exhibitors may begin moving out their exhibits by hand.

Load the exhibits onto vehicles parked at the "open-air exhibition area."
After being loaded, the vehicles must leave promptly.

A vehicle for high lift work for use by the Operational Secretariat will enter.

17:20 -Power supply inside the booths will be stopped.

17:30 -Decorations taken away by decoration companies begin.

18:00 -Move-out of large-sized exhibits using vehicles in the hall begins by the exhibitors.

19:00 -Move-out of large sized decorations using vehicles in the hall by the decoration companies begins

21:00 - Final cleaning begins.

*** For security reason, removal of decorations by decorators is not allowed until 17:20.**

■ Working in the Passage

All unloading, loading, unpacking and packing of display materials must be done inside the booth. Please do not block the passage ways.

Any and all remaining exhibition or decoration material is the responsibility of each exhibitor and must be taken away.

If anything is left in a public area, JGF Operational Secretariat will consider it scrap and dispose of it.

Please note that any and all disposal costs generated by left behind materials will be borne by the exhibitor.

List of Application Forms

■ Please submit application forms before the deadline.

All exhibitors must submit the application “forms A, B and C” by e-mail.

Other application forms are optional. The forms submitted after the deadline will be invalidated.

*Please download the forms from our website.

	Application Form	Deadline	Target
A	Registration of Decorating Company	31 Jan.	All Exhibitors
B	Application for Supply of Electricity/ 2nd Stage Trunk-Line Electrical Work	9 Feb.	All Exhibitors
D	Application for Floor Construction	9 Feb.	Optional
E	Application for Approval for Bringing Hazardous Material/the Use of Fire	31 Jan.	Optional
F	Application for Ceiling Construction	9 Feb.	Optional
I	Application for Furniture Rental	23 Feb.	Optional

Payment other than exhibition fee

■ Booth Decoration Work Fee

The invoice of booth decoration work fees, rental furniture fees, and electricity power fees will be sent before the Fair.

Payment method is cash or credit card. As we may not be able to use your credit card, we recommend cash payment.

A staff of Operational Secretariat will visit your booth during the Fair. Please prepare the exact amount because we don't have changes.

Guideline for Decoration and Exhibition - 1

■ Submission from the decorating company and a plan of the booth

All exhibitors are required to submit a “Form A (Registration for Decorating Company)”. Please attach a plan of your booth. /The Deadline is 31 Jan./

*Please write “N/A” and submit Form A, even if you are not using a company to help decorate your booth.

■ Submission from the decorating company and a plan of the booth

	1 or 2 booths with A type	3 or 4 booths with A type	More than 6 booths with A type	B type	Hitting Booth with Display Space	Wall Exhibition Type
Regulation	2.7m	2.7m	2.7m	2.7m	2.7m (Display Space)	2.7m
50cm set back from the path and the dividing line	2.7m	3.6m	6.0m			

* If your booth(s) are located next to Meeting Spaces, Exhibitors Space, or the wall of the venue, the setback rule will be not applied.

■ The Specification and Instructions

The unit wall(s) of a basic booth consist of crosspieces, poles, and panels.

Crosspieces and poles: silver (Aluminum)

Panels: white (color selection is possible for an additional charge)

The unit walls will be reused (for environmental considerations) therefore; all exhibitors will not be permitted to do any of the following actions to the wall: Nailing, tacking, or using any adhesive other than double sided tape.

If any damages on a unit panel are detected, repair fees will be charged to the exhibitors.

Display tools for a unit panel are available for a charge from the Operational Secretariat.

Please contact YKY Inc. if you are planning to use cutting sheets or similar items.

■ Furniture Rental

There are a variety of items available for rentals that are useful in the booth during the Fair. Please fill out the application “Form I” and submit it **by 23 Feb.**

We will inform you of the invoice at later date.

* Refer to separate catalog

Guideline for Decoration and Exhibition - 2

■ Constructor for Booth Decoration

JGF Operational Secretariat provides package plans and rental furniture for booth decoration. Exhibitors needing a constructor for booth decoration can ask the following company.

YKY Inc.

Contact person: Mr. Yamaguchi

Tel: +81-3-6206-8228 E-mail: info@yky.co.jp

■ Decorating Materials

There will be monitoring and inspection by the fire department during the installation period and during the Fair itself. If any violations are found, the work may be stopped, and/or a structure may be ordered to be dismantled. Therefore, please observe the following rules;

- 1) Please make sure that all plywood, linden plywood and print plywood to be used for exhibits has been treated with fire resistant maceration processing and bear a seal on the surface showing compliance with the "Ministry of Home Affairs Ministerial Ordinance of Autonomy, Fire Fighting Law and Construction Rule Article IV"
- 2) All combustible materials such as flags, banners, curtains, carpets, artificial flowers, papers, cloth and all other flammable materials, must be treated with effective flame-resistant processing. For items with flame-resistant processing already completed, please show the checkup mark or the acceptance mark to the relevant administrative agency. Flame-resistant plywood that is covered or pasted entirely with a thin cloth, paper or other flammable material is regarded as flame-resistant plywood. Plywood on which a thick cloth or paper with frills appended, partially appended, or attached with metal fittings and nails, is not regarded as an unitary item, so they will all need to have approved flame-resistant processing.
- 3) Petroleum products such as Styrofoam, Hong Kong flower, urethane and synthetic fibers which do not allow the penetration of flame-resistant solutions, may not be used. Only carpets that have undergone flame-resistant processing for fire prevention rules covered by "the Fire Fighting Law, Construction Rules, Article IV, and Paragraph 3" may be used. The use of all other items is prohibited. Please make sure that the "Flame-resistance processing label" is easy to see during the installation and construction work.
- 4) The installations of any materials or devices which may cause an accident, be harmful to visitors/exhibitors or that create any type disturbances are strictly prohibited.
- 5) Only legally fireproofed materials are accepted for use as; a net, a target, artificial lawn and including all decorations and exhibits.

Guideline for Decoration and Exhibition - 3

■ Other Points of Caution Related to Exhibition and Work Execution

1) With regard to ceiling structures, hanging decorative items from the ceiling of the booth is prohibited as a rule:

However, please speak with the Operational Secretariat **by 31 Jan.** if a ceiling structure is necessary for unavoidable reasons. The Secretariat will consult with the Fire Authority and when approval or denial is obtained, you will be notified.

2) Protection and security of the exhibition hall:

Using nails, scotch tape, or other adhesive materials directly on fixtures, ceilings, or pillars of the hall is not permitted. All construction and installation work done by exhibitors must be confined within the booth(s) allocated by the JGF. No item or work may go beyond the booth into the passageway.

3) The basic booth structure cannot be changed:

The basic structure of the booths constructed by the JGF may not be expanded, shrunk, moved, or dismantled.

4) Securing the passageway:

When decorating the booth or removing the decorations, please avoid placing any materials or goods along, in front of or between the booths. All the work must be done within the booth. Do not leave extra stock or decoration materials at the back walls of the hall.

5) Disaster prevention facilities:

Exhibitors are not permitted to move facilities such as emergency exits, fire extinguishers, smoking areas, or to obstruct securing of the necessary space for these facilities that have been set up by the Operational Secretariat.

6) Securing safety within the booth:

Each exhibitor is expected to secure adequate space for people to get in and out of the booth exit facing the passageway. Depending on the size and shape of the booth, please set up two or more exits when necessary.

7) Floor Construction:

Exhibitors must submit **“Form D” by 9 Feb.** if they need to do floor construction for an anchor bolt. Permission from PACIFICO YOKOHAMA authorities is required for this type of construction. Exhibitors are responsible for the installation and the removal work of the bolts (by cutting the bolts sticking out from the floor) after moving out their exhibits.

Exhibitors will be charged a repair expense of JPY 1,500 per bolt. The payment must be made during the Fair by cash or credit card.

8) Others:

If there are any questions or problems with regards to exhibition or work execution, or other similar situations, please consult the Operational Secretariat.

Supply of Electricity - 1

*The package plans for each type of booth include power supplies in sets, so exhibitors do not need to apply for a power supply. However, you will need to make an additional power supply application in the event that you require a powersupply with a capacity greater than that included in the set (additional application).

*Wall Exhibition Booth Type includes a power supply in a set, so no package plan is available.

■ Supply of Electricity

When electricity is used for demonstrations and lighting, the expense will be borne by the exhibitor. The electrical work for demonstrations and lighting (the wiring work up to each booth to the power switch) will be carried out by a contractor designated by JGF Operational Secretariat (the 1st stage trunk line electrical work).

All the electrical work done in the booth after setting up the power switch (the 2nd stage trunk line electrical work) will be done by the exhibitor at their expense.

■ 1st Stage Trunk-Line Electrical Work (consumption tax not included)

Single phase 100V,200V 1st stage work cost	Up to 1 KW	JPY 15,000	Three phase 200V1st stage work cost	Up to 1 KW	JPY 15,000
	For each additional 1 KW	JPY 15,000		For each additional 1 KW	JPY 15,000

■ Setting up a Distributor Panel

When the total volume of single-phase electricity exceeds 1,500W, a distributor panel must be installed in the second stage work.

* Please set the fire extinguisher beside the distributor panels.

■ Assumption of the Cost for the 2nd-Electrical Work

Electrical work from the trunk line side (on the first-stage) wired by the organizer to wiring inside the booth for lights, power and other electrical work (the second-stage work) shall be carried out by each exhibitor. The cost of such work will be borne by the exhibitor.

■ Application for 1st Stage Trunk-Line Electrical Work

In the case of using electricity in your exhibition, demonstrations, or lighting within the booth, please calculate the necessary amount of electricity and submit “Form B” to the Operational Secretariat **by 9 Feb**. The JGF will be unable to supply electricity, if your application is not received by the due date.

Supply of Electricity - 2

■ Application for 2nd Stage Trunk-Line Electrical Work

Exhibitors who need the second-stage trunk-line electrical work must submit **“Form B”** to the Operational Secretariat **by 9 Feb.**

Second stage- trunk-line electrical work provides installation for wiring work inside your booth, machine wiring work, lighting work, and outlet work.

2 prong receptacle	JPY 2,500 /1 place	Spot Light (LED)	JPY4,000 /1 lamp
Arm Spotlight (LED)	JPY 4,000 /1 Lamp	100W Spotlight (Halogen bulb)	JPY 4,500 /1 lamp
Seamless Light (LED)	JPY 4,000 /1 Lamp	300W Spotlight (Halogen bulb)	JPY 6,500 /1 lamp

*Consumption tax is not included in the price above.

■ Electricity rate

The electricity rate is included in 1st stage trunk-line electrical work.

Time period for supply of electricity

Electricity will be supplied **from 12:00** for booths with installation completed on **7 Mar. (Wed.)**.

When booths are still under construction the electricity will continue until the construction is completed. The time will be extended by 30 minutes before and after opening and closing hours. The power supply will be stopped at **17:20** on the last day.

*Please make sure to turn off the power switch in the booth (the main power switch) before leaving the hall.

Supply of Electricity - 3

■ Points of Attention for Executing Electrical Work

*All exhibitors are required to submit the “**Form B**” by **9 Feb.** Please make all payments during the Fair.

- 1) Any person(s) doing electrical work must have and carry an electrical technician’s license while working, based upon the provision in the electrical work law.
- 2) When an exhibition item is damaged due to an abnormality or an accident in the electrical power, such as a blackout or fall in the electrical voltage, at JGF Operational Secretariat shall not be held liable. Exhibitors are requested to adopt adequate protective devices.
- 3) No electrical work will be permitted during the Fair.
- 4) When doing wiring with a long extension cord, connecting one cord to another without the use of a connector is prohibited.
- 5) For wiring, an F cable or a cable on the same level (or higher) must be used. Wiring by vinyl cord, the use of a cable tap, or placing multiple wiring loads on one outlet is prohibited.
- 6) When doing floor wiring work, please protect the wiring with some type of protective covering material.
- 7) Please use proper fuses.
- 8) When doing electrical work, please pay utmost attention to fire prevention and other hazards that may cause accidents resulting in injuries or damage to property.
- 9) Please observe all of the points of concern and caution provided by at JGF Operational Secretariat in relation to electrical work.

*If you have any questions about electrical work, please contact JGF Operational Secretariat.

Points of Attention for the Fire Prevention - 1

■ Organizing a Voluntary Fire Prevention Group

During the time of the JGF, we will organize a group (of exhibitors) for fire prevention and the committee will take the liberty of appointing members from among the exhibitors.

We ask all exhibitors who are appointed to provide us with your cooperation.

■ Smoking in the Exhibition Hall

Smoking is prohibited in all areas.

■ Bringing in Hazardous Materials are prohibited

In compliance with Article of the Fire Prevention Ordinance of Yokohama city, the following activities are prohibited in the Fair halls.

If needed, you are requested to submit **"Form E"** to JGF Operational Secretariat **by 31 Jan.** JGF Operational Secretariat will apply to the fire department to obtain; "the approval for the temporary suspension of prohibition on specified activities."
" However, when the conditions in the approval are not carried out faithfully, the approval may be canceled. Please take note of this point.

*To obtain approval, there will be a visit to check and confirm the content of your application form the day before the Fair begins. Please make sure that your representative is there for this visit.

■ Prohibited Activities

- 1) Smoking: smoking in the booths is strictly prohibited.
- 2) Use of open flames or equipment that emits flames or sparks, electrical heaters with exposed Nichrome wires, kerosene stoves, or alcohol lamps.
- 3) Bringing in liquefied petroleum gasses or other high pressured gas items.
✂Ex. Spray can containing LPG gas is also hazardous materials.
- 4) Bringing in hazardous materials such as gasoline, kerosene, machine oil, fuel oil, etc.
- 5) Other hazardous materials such as; paints, certain types of toner for photo copies, sprays, high pressure cylinders, explosives, and nuclear fuel substances.

If needed, please submit the **"Form E"** to JGF Operational Secretariat **by 31 Jan.**

■ Quantitative Restrictions

- 1) Hazardous materials and semi-hazardous materials are to be under 10% of the designated amounts set in the fire defense law. No such materials for exhibition or for sale are permitted.
✂In cases of exhibition or demonstration by such as spray cans containing LPG gas, its limit of the quantity is refer to the other guide.
- 2) Combustible gas must be stored in a type of container that is within the scope of application of the high pressure gas control law with the maximum volume must be less than 2 kg and the total gas volume must be less than 5 kg.

Points of Attention for the Fire Prevention - 2

■ Location of Hazardous Materials

- 1) Hazardous materials must be placed a safe distance from all surrounding combustible materials and far enough from the standpoint of fire prevention.
- 2) Materials must be at least 6 meters away from the emergency exit, staircase, and any place where fire is being used. If there is an effective fire wall (from the standpoint for fire prevention) that situation will be regarded as an exception.

■ Safety Measures

- 1) Please devise safety measures for monitoring by your representative who is responsible for fire prevention in your booth as well as for inspection after each use.
- 2) When a hazardous material or semi-hazardous material is being heated or boiled, the volume of such material should be under 60% of the container capacity.
- 3) When you bring in a container of liquefied petroleum gas, use the cartridge type fuel tank.
- 4) When you handle a hazardous liquid material, the pipes should be metal; the joints should be screw-type, flanged or welded.
- 5) When there is a significant amount of combustible vapor emitted, please set up a device for exhausting the vapor safely outside.
- 6) If you have any machinery or equipment from which hazardous liquid material could scatter, please take the necessary precautions against scatter liquid.
- 7) If you will handle hazardous materials which may ignite if they come into contact or get mixed with other hazardous materials, please make sure that you do not handle them in the same area.
- 8) During the Fair is open, please do not replenish any hazardous liquid materials.
- 9) The amount of fuel in the tanks of equipment and machines that are exhibited or displayed should be at the minimum level.
- 10) Please do not use any hazardous material whose name and/or properties you are not totally clear about.
- 11) Please take all other necessary safety measures for the hazardous materials you will handle in accordance with their respective properties.
- 12) Fix the position of any equipment that uses fire to the floor or to the wall so that it will not easily move.

Demonstrations and Advertising Activities - 1

■ Points of Attention When Doing Demonstrations

We ask that exhibitors who will carry out demonstrations be very mindful of safety, and that all precautions are taken to prevent injury and damage to your own or other exhibitors' assets. Compensation for any damage to exhibitors' assets or to visitors to the Fair caused by demonstrations is to be resolved by the responsible exhibitors. Please carry out all demonstrations inside of the booth. During a demonstration, no equipment or demonstrators may protrude into the passageway. No flyers may be distributed along the passageway. Any items including chairs, tables or equipment may not be brought into the passageway.

Illumination levels should be adjusted so that they do not interfere with other exhibitor's displays or visitors to the Fair. If any problems are reported, JGF Operational Secretariat will be required to take the appropriate action to improve the situation.

■ Item Distribution to Visitors

Please be careful when distributing product bags with advertisements for your exhibits. There have been reports that exhibits and displays have been damaged and that children have been injured by bags that are large, sharp, and have hard corners.

■ Passageway Regulations

When presenting stage events and demonstrations, please do not block the passageway as it may cause an inconvenience to other exhibitors due to the extreme concentration of people at such events. Please note that if such events are identified to be a cause of inconvenience, JGF Operational Secretariat may request termination of such events and demonstrations.

■ Noise Regulation

If audio equipment is to be used for demonstrations in your booth, please make sure that the volume is set at an appropriate level so that it does not disturb adjacent exhibitors.

***The sound should be set below 75db and 3m away from the borderline of your booth.**

If complaints are received from adjacent exhibitors, JGF Operational Secretariat will ask the offending exhibitor(s) to follow the appropriate volume level.

Demonstrations and Advertising Activities - 2

■ **Speaker-Position Regulation**

Speakers should not face directly towards adjacent exhibitors. They should face the inside of the stage. If speakers are positioned on the wall or the poles facing the passageway, the angle should be below 45 degrees.

If speakers are positioned on the stage, the central axis should face the center of the stage.

If complaints are received from adjacent exhibitors, JGF Operational Secretariat will ask the offending exhibitor(s) to follow the appropriate rules.

■ **Photographs**

Taking photographs in the Fair area:

1) It is prohibited to photograph or to sketch an exhibit without the exhibitor's permission.

2) Visitors to the Fair are allowed to take photographs. In the case of exhibitors needing to maintain trade secrets regarding equipment, functions, or designs, the exhibitors are allowed to ask visitors to refrain from taking photographs.

3) Exhibitors photographing their own booths:

When exhibitors need to take photographs of their own booths, we ask those exhibitors to not to inconvenience visitors to the Fair. If you would like to take photographs outside of the opening or closing times, please submit the "Overtime work notification" to JGF Operational Secretariat in advance of taking the photos.

4) Photographs by member of the Press:

The Operational Secretariat provides press members with armbands marked "PRESS," and requests exhibitors to cooperate with photographers wearing these armbands.

Demonstrations and Advertising Activities - 3

■ Temporary Communication Line

There is LAN Service in the hall. It may not be usable by a line congestion and electric wave disorder.

Communication Line installed

If you plan to demonstrate via internet during the Fair, please contact below.

◀ The Deadline is 31 Jan. ▶

Deadline:

PACIFICO YOKOHAMA Exhibitor Operation group

Contact: Takeuchi

TEL: +81-45-221-2183 / FAX: +81-45-221-2184

E-mail : takeuchi@pacifico.co.jp

Inquiries

Japan Golf Fair Operational Secretariat

Email : exhibitor@japangolffair.com

Regulations on Sale within exhibitor booths

- 1) Products to be sell should be limited to our own products or those of affiliated companies.
- 2) Second-hand items are prohibited to sell.
- 3) On last day of the exhibition, estimated sales amount should be report the management office.
- 4) Exhibitors are responsible for all operations related to sales, such as product management, sales management, product safety, and after-sales follow-up to purchasers.
- 5) Selling outside from your booth is prohibited.
- 6) All items for sale must be stocked in your own booth.
*There is no public stock space available.
- 7) Products to be sell must be accompanied by a sticker provided by the management office.
*Please pick it the sticker at the management office on the day for setup.

For payment, we recommend credit cards, which are widely used in Japan, or cash in Japanese Yen.

Maintenance and Management of the Fair

■ Management and Exemption of Liability for Exhibit Items

JGF Operational Secretariat will contract with a security company to monitor and to provide security for the entire period of the JGF. This will include from the time of installation to the time of moving out exhibited items after the Fair. However, JGF Operational Secretariat will not be held responsible for any damage, loss or theft to exhibited items.

A representative of your company must be stationed at all times in your booth to manage the exhibit, as well as to attend to visitors. Please pay utmost attention to the handling of cash and valuables during the Fair.

■ Damage Compensation

If an exhibitor or any of its representatives cause damage to another exhibitor's booth or exhibited items, to the JGF equipment, to PACIFICO YOKOHAMA equipment, to exhibition facilities, to visitors or other persons on the Fair grounds, the exhibitor will be held liable for damage compensation.

■ Cleaning inside the Booth

Exhibitors will be responsible for the maintenance and cleaning inside their booth. Exhibitors are responsible for the removal and disposal of all materials from the exhibition. All exhibited items must be taken away. When items used for an exhibit are left behind, JGF Operational Secretariat will consider them as scrap and dispose of them. Please note: JGF Operational Secretariat will charge exhibitors disposal costs generated by left behind items from their booth.

■ Exemption from Responsibility

Due to a natural disaster or other circumstances beyond its control, JGF Operational Secretariat may be compelled to change the dates of the Japan Golf Fair or cancel the Fair. We do not assume the responsibility or the guarantee of damages that may occur as a result of such natural disasters, changes or cancellations. The expenses incurred up to that time will be borne by the exhibitors in accordance with the number of booths applied for.

JGF Operational Secretariat reserves the right to change the content of this Exhibitor Service Manual in part, and in that case, the rules after such change(s) will have precedence.

Regulations for exhibitions and PR activities

- 1) To takes all possible measures to prevent accidents, the organizer provides security guards stationed at the venue 24 hours a day throughout the entire period from loading to un-loading, However We are not responsible for any personal injury or property damage.
- 2) During the event an exhibitor causes personal or property damage to visitors, other exhibitors, or other third parties at the venue, the exhibitor will fully responsible and the organizer will not be held responsible.
- 3) All promotions, advertisements, and sales activities shall be limited to the company's booth.
- 4) Exhibitors are responsible for ensuring that the aisles near their booths are not congested for PR activities.
- 5) No decorations or anything beyond the bounds of the booth's assigned use.
- 6) The organizer reserves the right to prohibit or remove all acts that are not in line with the purpose of the exhibition, such as decorations and exhibits that are deemed problematic due to their sound, usage, materials, or other reasons.
- 7) Due to the above restriction or removal, the Organizer shall not be liable to Entrant for any refund or other related costs.

About exhibits

- 1) The Exhibitor shall notice the Organizer that printed materials or other media related to the Exhibits may be subject to any third party's trademark rights, design rights, patent rights, utility model rights or other intellectual property rights and warrants that not infringe.
- 2) During the event if the exhibitor claims to the organizer that its conduct related to exhibiting at the exhibition infringes on the intellectual property rights such as trademark rights of a third party, the exhibitor shall immediately take responsibility for it. We are obliged to resolve disputes with third parties and not interfere with the normal and smooth progress of the exhibition.
- 3) Group exhibition case also assume the same obligations as in the preceding paragraph regarding intellectual property rights infringement claims from third parties against applicants who are members of the group.

Inquiries

Japan Golf Fair Operational Secretariat
Email : exhibitor@japangolffair.com